

SST-12-WS Gen 2

High Power White LEDs



Features

- A round emitter delivers superior beam quality and higher optical efficiency than square emitters for directional lighting applications.
- The vertical chip's high lumen density reduces the optics' size while maximizing the intensity and beam distance.
- The phosphor-on-chip technology features high color uniformity over radiation angle, enabling superior light quality for beam spots.
- Maximum Drive Current: 2.4 A
- Color Temperature: 5000K, 5700K, 6500K
- Color Rendering Index: Typ. 70, Min. 65
- Low thermal resistance: 4.9 °C/W
- ANSI-compatible chromaticity bins
- Electrically isolated thermal path
- 8 kV HBM ESD rating per ANSI/ESDA/JEDEC JS-001



Applications

- Compact Portable Lights
- Bicycle Lights
- Automotive Auxiliary Lights
- Stage & Studio Lighting
- Outdoor Lighting
- LED Work Lights

Table of Contents

| | |
|-------------------------------|----|
| Ordering Information..... | 2 |
| Binning Structure..... | 3 |
| Absolute Maximum Ratings..... | 6 |
| Product Characteristics..... | 6 |
| Soldering Profile..... | 10 |
| Mechanical Dimensions..... | 11 |
| Tape and Reel Outline..... | 12 |
| Shipping Label..... | 13 |
| Packaging..... | 14 |
| Notes..... | 15 |



Ordering Information

Ordering Part Numbers¹

| CRI | CCT | Luminous Flux | | Chromaticity Bin Kit ³ | Ordering Part Number |
|--------------------|-------|-------------------------------|---------------------------|-----------------------------------|----------------------|
| | | Minimum Flux Bin ¹ | Minimum Flux ² | | |
| Typ. 70 Min. 65 | 5000K | D3 | 295 lm | 501 | SST-12-WS50-A2-D3501 |
| | | | | 502 | SST-12-WS50-A2-D3502 |
| | | D4 | 310 lm | 501 | SST-12-WS50-A2-D4501 |
| | | | | 502 | SST-20-WS50-A2-D4502 |
| | 5700K | D3 | 295 lm | 571 | SST-12-WS57-A2-D3571 |
| | | | | 572 | SST-12-WS57-A2-D3572 |
| | | D4 | 310 lm | 571 | SST-12-WS57-A2-D4571 |
| | | | | 572 | SST-12-WS57-A2-D4572 |
| | 6500K | D4 | 310 lm | 651 | SST-12-WS65-A2-D4651 |
| | | | | 652 | SST-12-WS65-A2-D4652 |
| | | D5 | 325 lm | 651 | SST-12-WS65-A2-D5651 |
| | | | | 652 | SST-12-WS65-A2-D5652 |

Part Number Nomenclature

SST

12

W<xy>

<p#>

<ffccc>

| Product Family | Chip Area | Color | Package Configuration | Bin Kit |
|--|-------------------------|--|--|--|
| S: Surface Mount S: Dome Lensed T: Single Emitter | 12: 1.2 mm ² | W: White <x> CRI Category Code S: CRI>65 <yy> Color Temperature 50: 5000K 65: 6500K | <p> Solder Pad Configuration A: type A - see page 11 <#> Chip Generation 2: Gen 2 | <ff> Minimum Flux Bin, see 'Luminous Flux Binning' table for details <ccc> Chromaticity Bin Kit, see 'Chromaticity Bin Kit Codes' table for details |

Note:

- The Ordering Part Number specifies the Minimum Flux Bin in shipment; higher flux bins may be shipped without advance notice. Please refer to 'Luminous Flux Binning' table for details of all flux bins.
- Product test condition: I_f = 700 mA, T_j = 85°C.
- Shipments always adhere to the color bins specified in each Chromaticity Bin Kit. See 'Chromaticity Bin Kit Codes' table for the color bins included in each Bin Kit.



Binning Structure

Luminous Flux Binning^{1,2}

| Flux Bin Code | Binning @ 700 mA | | | Correlated Minimum Flux (lm) @ $T_j=85^\circ\text{C}^2$ | | | |
|---------------|----------------------------|-------------------|--------------------------|---|---------|---------|---------|
| | $T_j = 85^\circ\text{C}^1$ | | $T_j = 25^\circ\text{C}$ | | | | |
| | Minimum Flux (lm) | Maximum Flux (lm) | Minimum Flux (lm) | 350 mA | 1000 mA | 1800 mA | 2400 mA |
| D2 | 280 | 295 | 314 | 154 | 378 | 594 | 722 |
| D3 | 295 | 310 | 330 | 162 | 398 | 625 | 761 |
| D4 | 310 | 325 | 347 | 171 | 419 | 657 | 800 |
| D5 | 325 | 340 | 364 | 179 | 439 | 689 | 839 |
| D6 | 340 | 355 | 381 | 187 | 459 | 721 | 877 |

Forward Voltage Binning³

| Voltage Bin Code ³ | Binning @ 700 mA, $T_j = 85^\circ\text{C}$ | |
|-------------------------------|--|---------------------|
| | Minimum Voltage (V) | Maximum Voltage (V) |
| VJ | 2.7 | 2.9 |
| VK | 2.9 | 3.1 |

Note:

- LEDs are measured at 25°C ambient temperature with 700 mA 20 ms single pulse. The measured values are correlated to values at 85°C junction temperature (T_j). Luminus maintains a $\pm 6\%$ tolerance on flux measurement.
- Flux values at other junction temperature (T_j) and/or forward current conditions are calculated and for reference only.
- Individual voltage bins are not orderable.



Binning Structure

Chromaticity Binning Coordinates

| CCT | Bin Code | CIE _x | CIE _y | Bin Code | CIE _x | CIE _y | Bin Code | CIE _x | CIE _y | Bin Code | CIE _x | CIE _y |
|-------|----------|------------------|------------------|----------|------------------|------------------|----------|------------------|------------------|----------|------------------|------------------|
| 5000K | DA | 0.3371 | 0.3490 | DB | 0.3376 | 0.3616 | DC | 0.3463 | 0.3687 | DD | 0.3451 | 0.3554 |
| | | 0.3451 | 0.3554 | | 0.3463 | 0.3687 | | 0.3551 | 0.3760 | | 0.3533 | 0.3620 |
| | | 0.3440 | 0.3427 | | 0.3451 | 0.3554 | | 0.3533 | 0.3620 | | 0.3515 | 0.3487 |
| | | 0.3366 | 0.3369 | | 0.3371 | 0.3490 | | 0.3451 | 0.3554 | | 0.3440 | 0.3427 |
| | DH | 0.3366 | 0.3369 | DE | 0.3381 | 0.3762 | DF | 0.3480 | 0.3840 | DG | 0.3440 | 0.3428 |
| | | 0.3440 | 0.3428 | | 0.3480 | 0.3840 | | 0.3571 | 0.3907 | | 0.3515 | 0.3487 |
| | | 0.3429 | 0.3307 | | 0.3463 | 0.3687 | | 0.3551 | 0.3760 | | 0.3495 | 0.3339 |
| | | 0.3361 | 0.3245 | | 0.3376 | 0.3616 | | 0.3463 | 0.3687 | | 0.3429 | 0.3307 |
| 5700K | CA | 0.3215 | 0.3350 | CB | 0.3207 | 0.3462 | CC | 0.3290 | 0.3538 | CD | 0.3290 | 0.3417 |
| | | 0.3290 | 0.3417 | | 0.3290 | 0.3538 | | 0.3376 | 0.3616 | | 0.3371 | 0.3490 |
| | | 0.3290 | 0.3300 | | 0.3290 | 0.3417 | | 0.3371 | 0.3490 | | 0.3366 | 0.3369 |
| | | 0.3222 | 0.3243 | | 0.3215 | 0.3350 | | 0.3290 | 0.3417 | | 0.3290 | 0.3300 |
| | CH | 0.3222 | 0.3243 | CE | 0.3196 | 0.3602 | CF | 0.3290 | 0.3690 | CG | 0.3290 | 0.3300 |
| | | 0.3290 | 0.3300 | | 0.3290 | 0.3690 | | 0.3381 | 0.3762 | | 0.3366 | 0.3369 |
| | | 0.3290 | 0.3180 | | 0.3290 | 0.3538 | | 0.3376 | 0.3616 | | 0.3361 | 0.3245 |
| | | 0.3231 | 0.3120 | | 0.3207 | 0.3462 | | 0.3290 | 0.3538 | | 0.3290 | 0.3180 |
| 6500K | BA | 0.3048 | 0.3207 | BB | 0.3028 | 0.3304 | BC | 0.3115 | 0.3391 | BD | 0.3130 | 0.3290 |
| | | 0.3130 | 0.3290 | | 0.3115 | 0.3391 | | 0.3205 | 0.3481 | | 0.3213 | 0.3373 |
| | | 0.3144 | 0.3186 | | 0.3130 | 0.3290 | | 0.3213 | 0.3373 | | 0.3221 | 0.3261 |
| | | 0.3068 | 0.3113 | | 0.3048 | 0.3207 | | 0.3130 | 0.3290 | | 0.3144 | 0.3186 |
| | BH | 0.3068 | 0.3113 | BE | 0.3005 | 0.3415 | BF | 0.3099 | 0.3509 | BG | 0.3144 | 0.3186 |
| | | 0.3144 | 0.3186 | | 0.3099 | 0.3509 | | 0.3196 | 0.3602 | | 0.3221 | 0.3261 |
| | | 0.3161 | 0.3059 | | 0.3115 | 0.3391 | | 0.3205 | 0.3481 | | 0.3231 | 0.3120 |
| | | 0.3093 | 0.2993 | | 0.3028 | 0.3304 | | 0.3115 | 0.3391 | | 0.3161 | 0.3059 |



Binning Structure

Chromaticity Binning Diagram^{1,2}

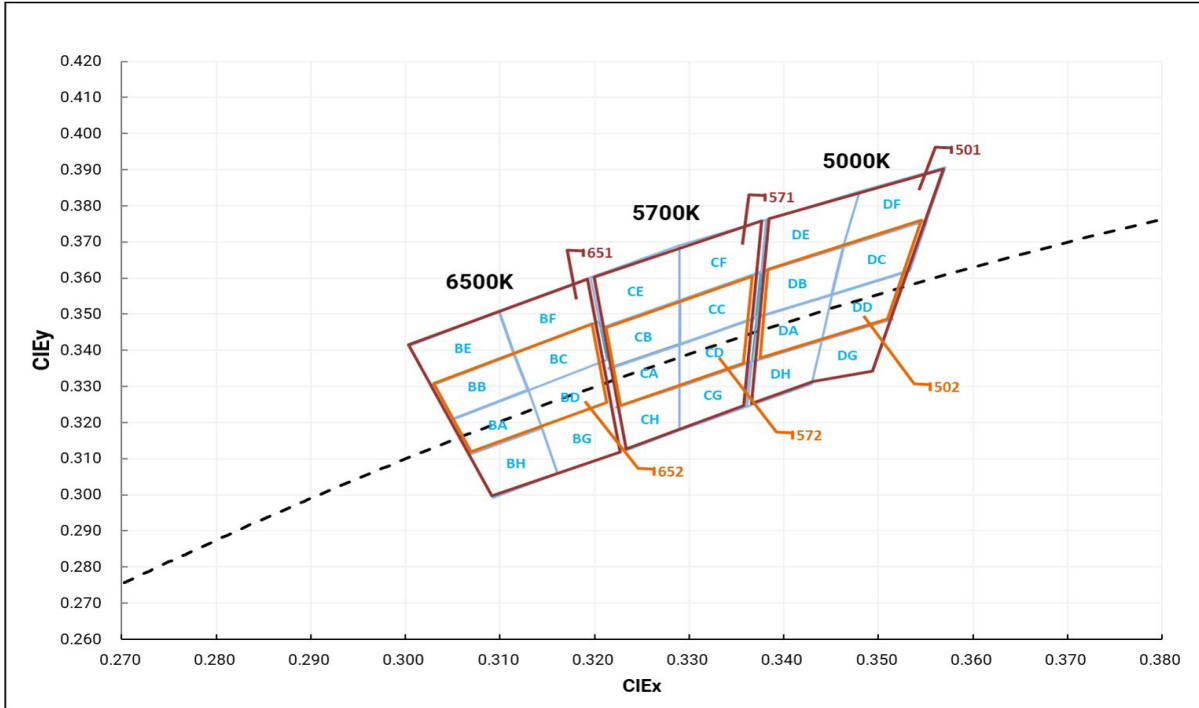

Chromaticity Bin Kit Codes

| CCT | Bin Kit | Chromaticity Bins |
|-------|---------|--------------------------------|
| 5000K | 501 | DA, DB, DC, DD, DE, DF, DG, DH |
| | 502 | DA, DB, DC, DD |
| 5700K | 571 | CA, CB, CC, CD, CE, CF, CG, CH |
| | 572 | CA, CB, CC, CD |
| 6500K | 651 | BA, BB, BC, BD, BE, BF, BG, BH |
| | 652 | BA, BB, BC, BD |

Note:

- LED chromaticity is measured and binned at 25°C ambient temperature with 700 mA 20 ms single pulse.
- Luminus maintains a tolerance of ± 0.005 on Chromaticity (CIE_x, CIE_y) measurement.



Absolute Maximum Ratings

| | | Symbol | Values | | Unit |
|---|---------|--------------------|-----------------------|-----------------------|------|
| | | | T _j =130°C | T _j =150°C | |
| DC Forward Current | Minimum | I _{f min} | 0.1 | | A |
| | Maximum | I _{f max} | 2.4 | 1.8 | A |
| Surge Current (t<10 ms, Duty Cycle < 10%) | | I _{s max} | 3.6 | 2.5 | A |
| Power Dissipation | | P _D | 8.0 | 6.0 | W |
| Reverse Voltage (@ I _f = 10 mA) | | V _r | 5 | | V |
| Junction Temperature | | T _{j max} | 150 | | °C |
| Operating Temperature | | T _{opr} | -40 to 100 | | °C |
| Storage Temperature | | T _{stg} | -40 to 100 | | °C |
| ESD withstand Voltage HBM Per ANSI/ESDA/JEDEC JS-001 | | V _{HBM} | 8 | | kV |
| ESD withstand Voltage CDM Per ANSI/ESDA/JEDEC JS-002 | | V _{CDM} | 1 | | kV |

Product Characteristics

| Parameter | | Symbol | Value | Unit |
|---|---------|----------------------|-------|-------|
| Color Rendering Index ¹ (T _j =85°C) | Minimum | CRI _{min} | 65 | |
| | Typical | CRI _{typ} | 70 | |
| Viewing Angle (FWHM) | | 2θ _{1/2} | 120 | ° |
| Forward Voltage (I _f =700 mA, T _j = 85°C) | Minimum | V _{f min} | 2.7 | V |
| | Typical | V _{f typ} | 2.9 | |
| | Maximum | V _{f max} | 3.1 | |
| Temperature Coefficient of Voltage | | ∂V _f /∂T | -1.4 | mV/°C |
| Thermal Resistance (Electrical) Junction/Solder Point | | R _{thjs-EL} | 4.9 | °C/W |

Note:

1. Luminus maintains a tolerance of ±2 on Color Rendering Index (CRI) measurement.



Maximum Permissible DC Current vs. Junction Temperature

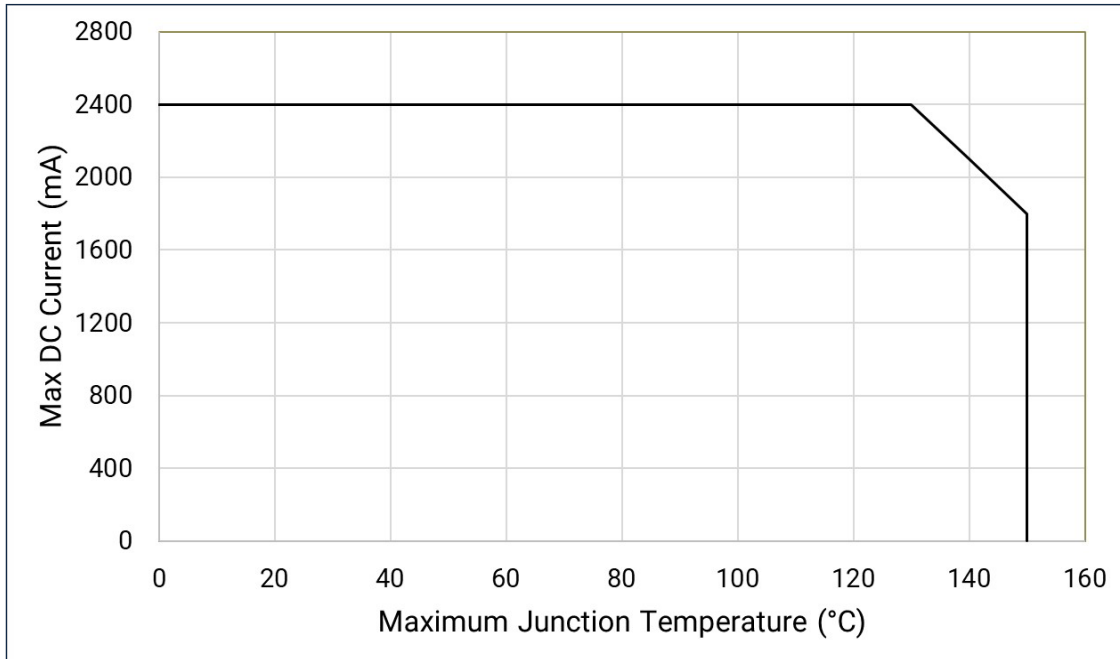



Relative Luminous Flux

Forward Current: $\phi_v/\phi_v(0.7\text{ A}), T_j = 85^\circ\text{C}$

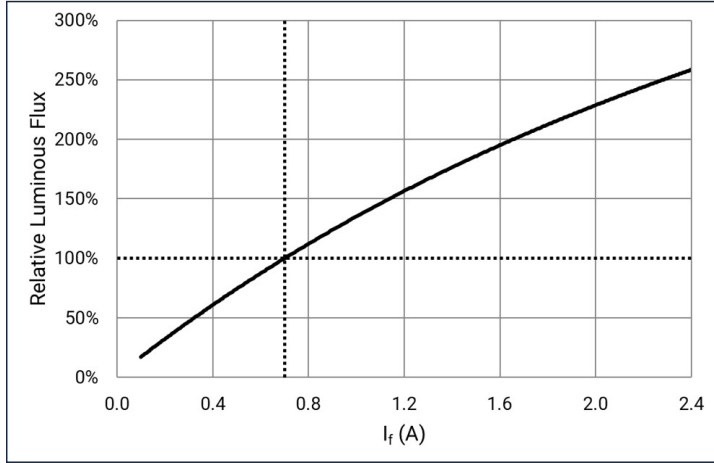

Temperature (T_j): $\phi_v/\phi_v(85^\circ\text{C}), I_f = 0.7\text{ A}$

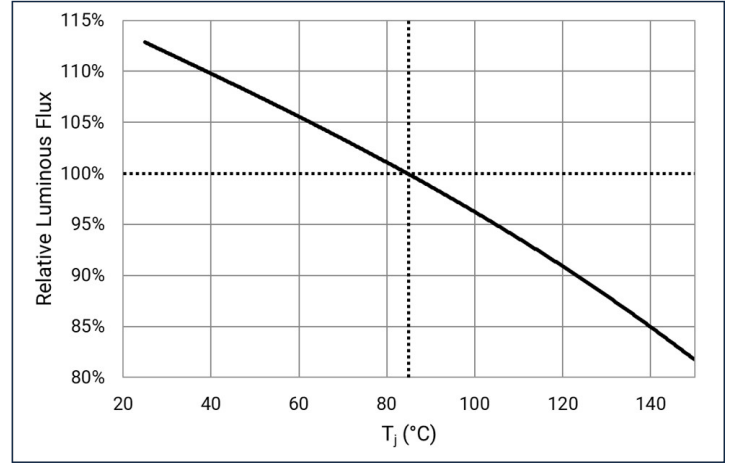

Forward Voltage

Forward Current: $\Delta V_f = V_f(I_f) - V_f(0.7\text{ A}), T_j = 85^\circ\text{C}$

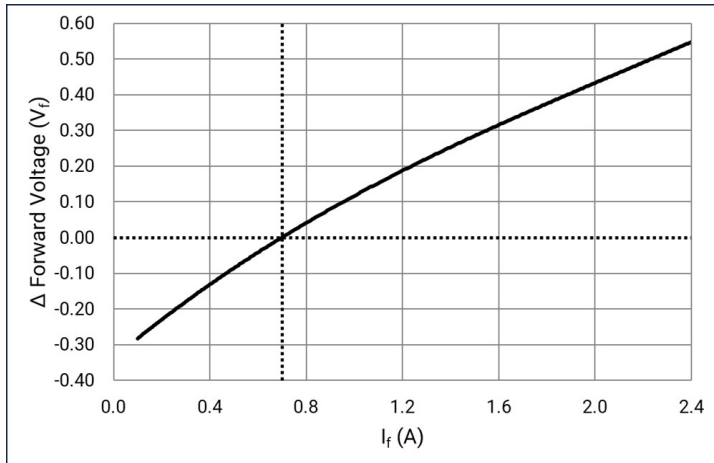

Temperature (T_j): $\Delta V_f = V_f(T_j) - V_f(85^\circ\text{C}), I_f = 0.7\text{ A}$

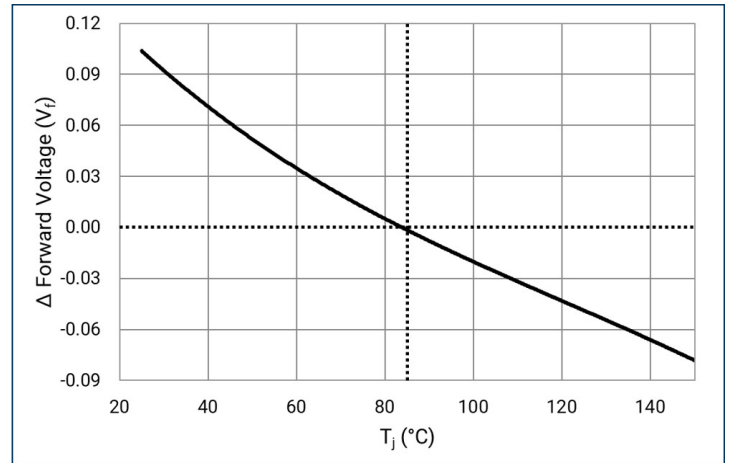

Relative Chromaticity

Forward Current: $\Delta \text{CIEx,y} = \text{CIEx,y}(I_f) - \text{CIEx,y}(0.7\text{ A}), T_j = 85^\circ\text{C}$

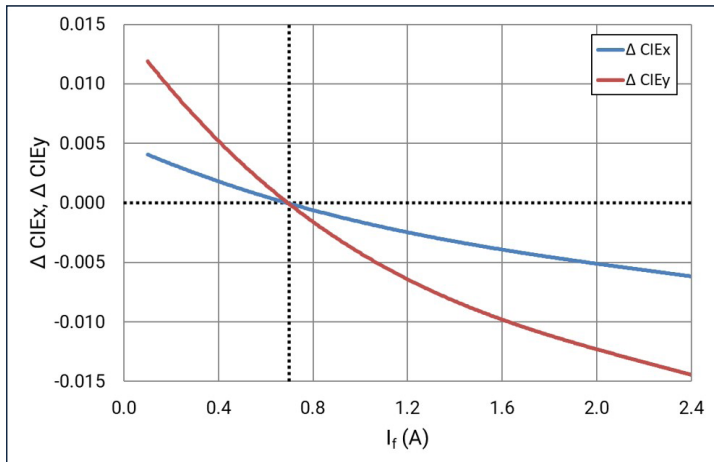

Temperature (T_j): $\Delta \text{CIEx,y} = \text{CIEx,y}(T_j) - \text{CIEx,y}(25^\circ\text{C}), I_f = 0.7\text{ A}$

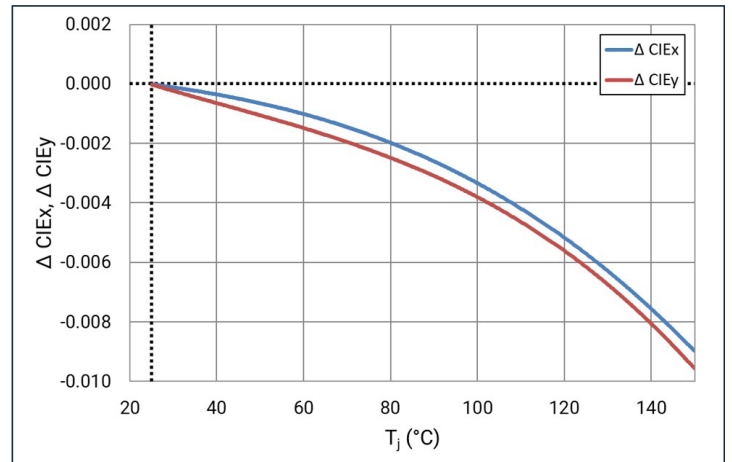



Angular Distribution

$I_f = 0.7 \text{ A}$; $T_j = 25^\circ\text{C}$

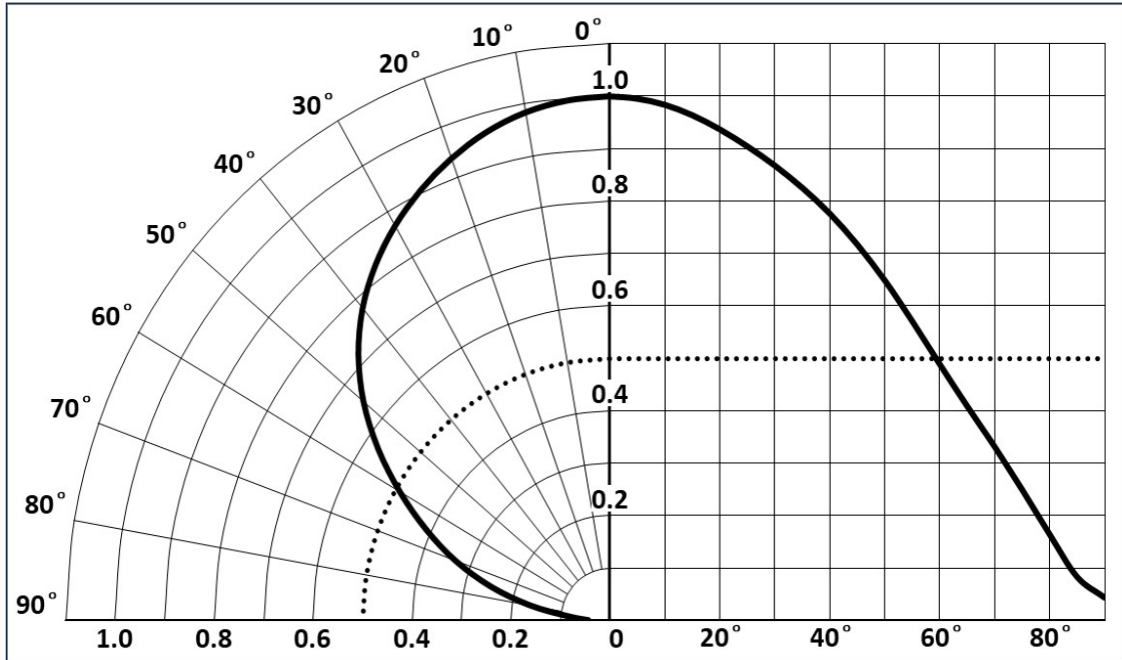

Relative Spectral Power Distribution

$I_f = 0.7 \text{ A}$; $T_j = 85^\circ\text{C}$

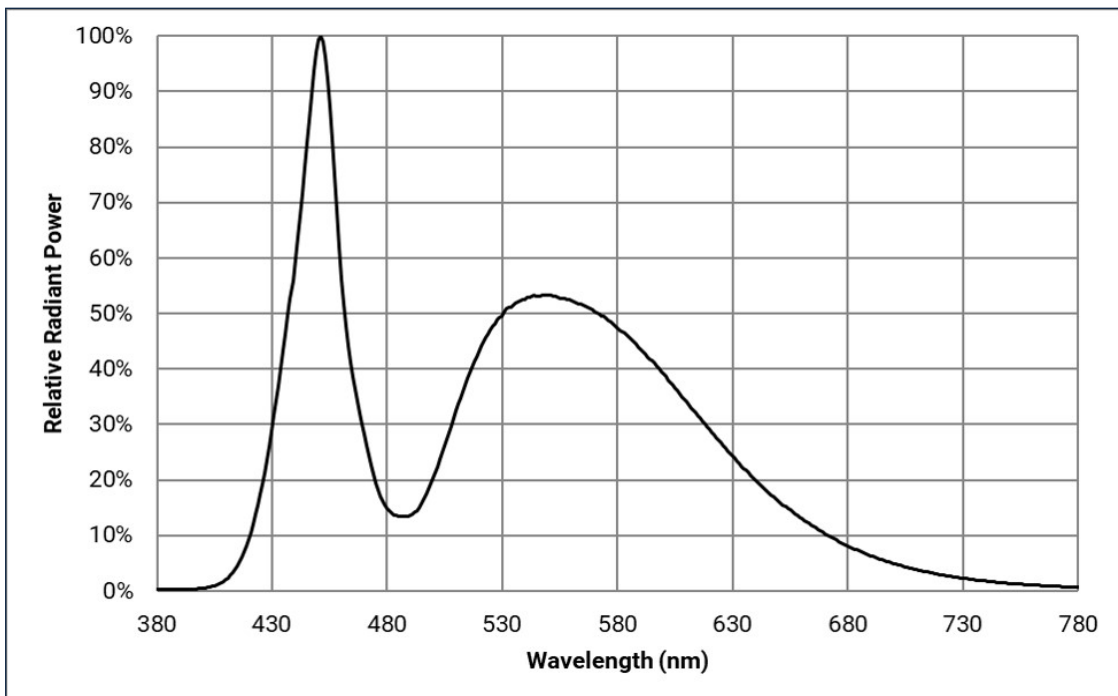



Soldering Profile

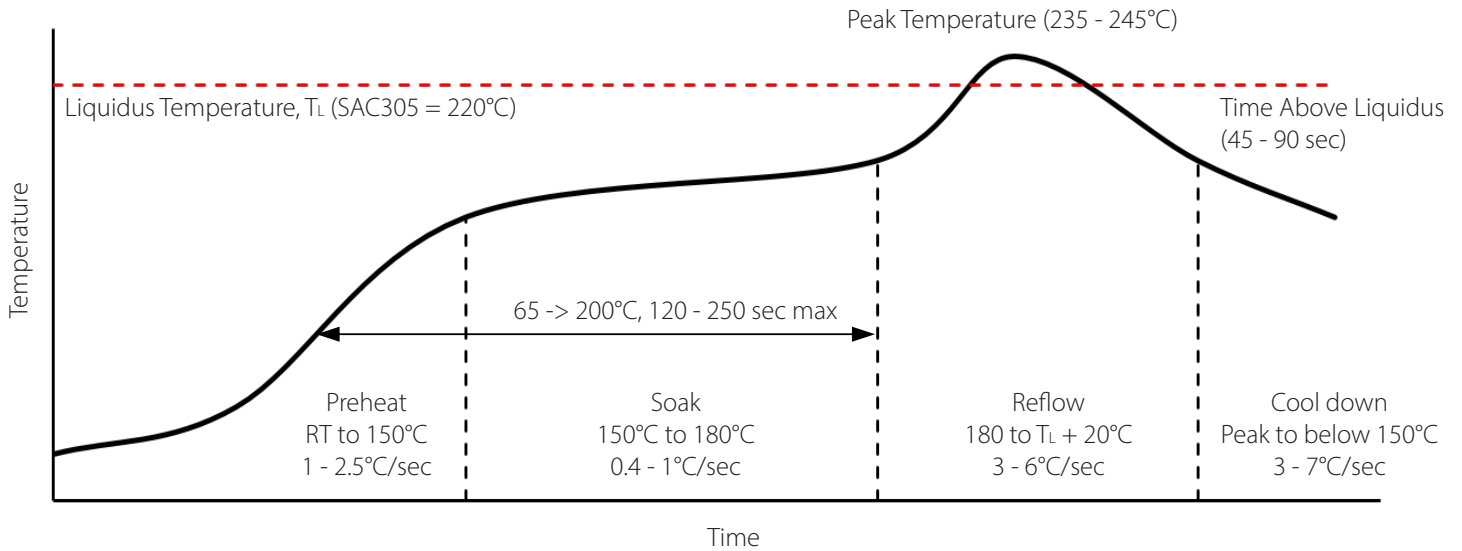

| SMT Rework Guideline | Manual Hotplate Reflow | Hot Air Gun Reflow |
|----------------------|------------------------|--------------------|
| Heating Time | < 60 sec | |
| Hotplate Temperature | < 245°C | < 150°C |

Note:

- Product complies to Moisture Sensitivity Level 3 (MSL 3).
- The numbers in the table are specific to SAC305. Luminus recommends using an SAC305 solder paste with a no-clean flux for RoHS compliant products.
- During the pick and place process, axial forces on the dome (or window) should not exceed 0.5 Newtons (N).
- Use of a multi-zone IR reflow oven with a nitrogen blanket is recommended.
- Time-temperature profile of the reflow process showing the four functional profile zones are defined in IPC-7801. Temperature is referenced to the center of the PCB.
- Luminus recommends to use the solder paste data sheet information as a starting point in time-temperature process development.
- These are general guidelines. Consult the solder paste manufacturer's datasheet for guidelines specific to the alloy and flux combination used in your application.
For more information, please refer to:
<https://luminusdevices.zendesk.com/hc/en-us/articles/360060306692-How-do-I-Reflow-Solder-Luminus-SMD-Components->
- For any technical questions about soldering process, please contact Luminus at techsupport@luminus.com.



Mechanical Dimensions¹

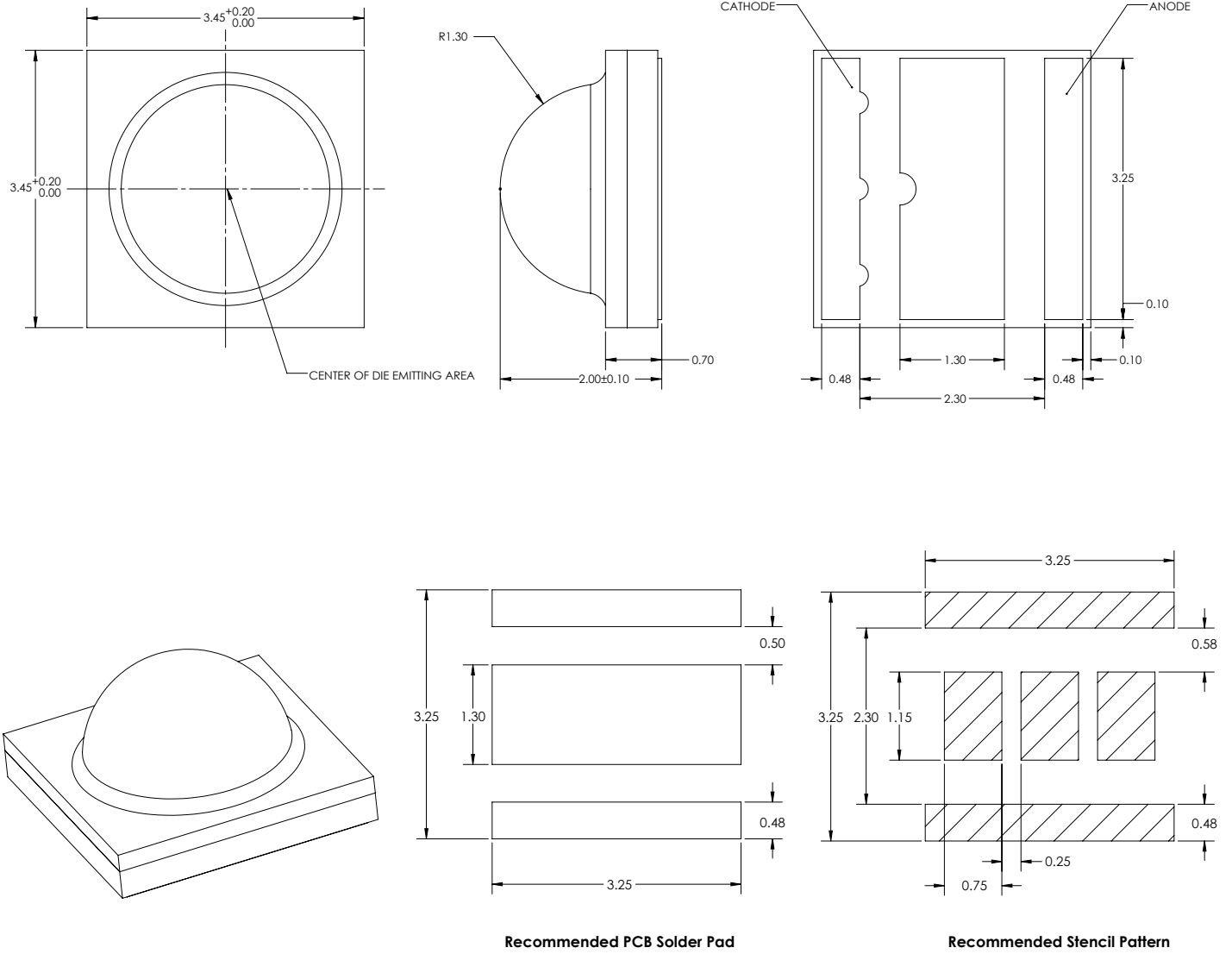

Note:

1. All dimensions are in millimeter ± 0.13 mm



Tape and Reel Outline

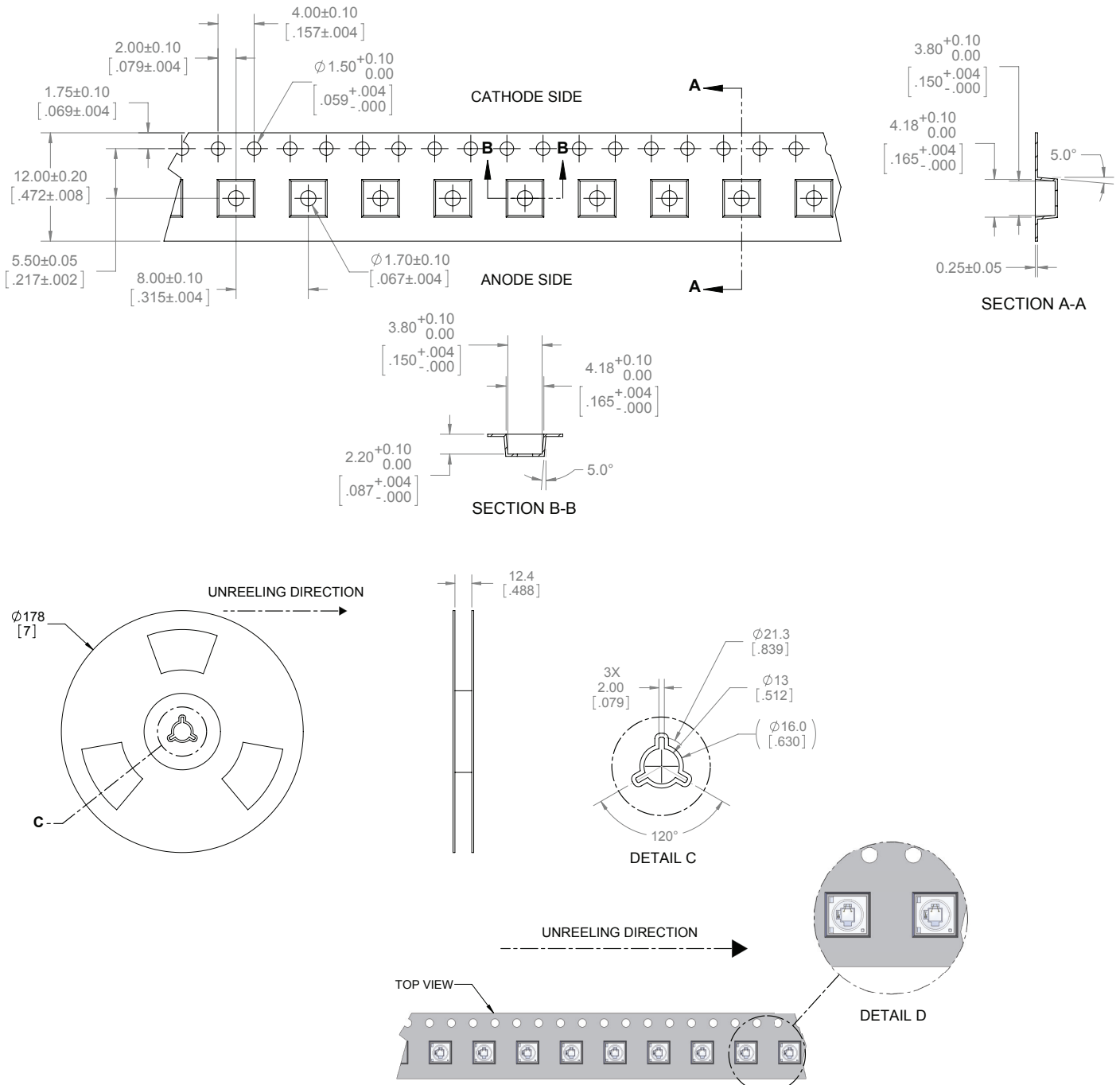

Note:

1. Each reel contains 1,000 units.
2. Leave 160 mm of type empty for lead in (20 empty pockets).
3. Leave 480 mm of type empty for trailer (60 empty pockets).
4. Must comply to EIA-481-C-2003.
5. Final tape and reel packaging must meet the requirements of JEDEC-STD-033, LEVEL 2A.



Shipping Label

Label on Packaging Box

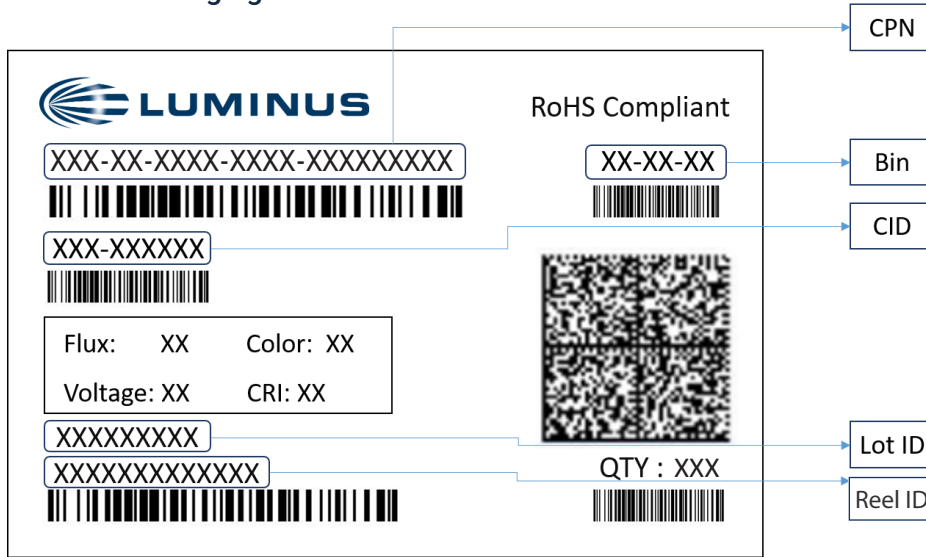

Label Fields:

- CPN:** Luminus ordering part number
- CID:** Customer's part number
- QTY:** Quantity of parts per reel
- Flux:** Bin as defined on page 3
- Voltage:** Bin as defined on page 3
- Color:** Bin as defined on page 4
- CRI:** NA
- Lot ID & Reel ID:** For Luminus internal use

Label on Reel

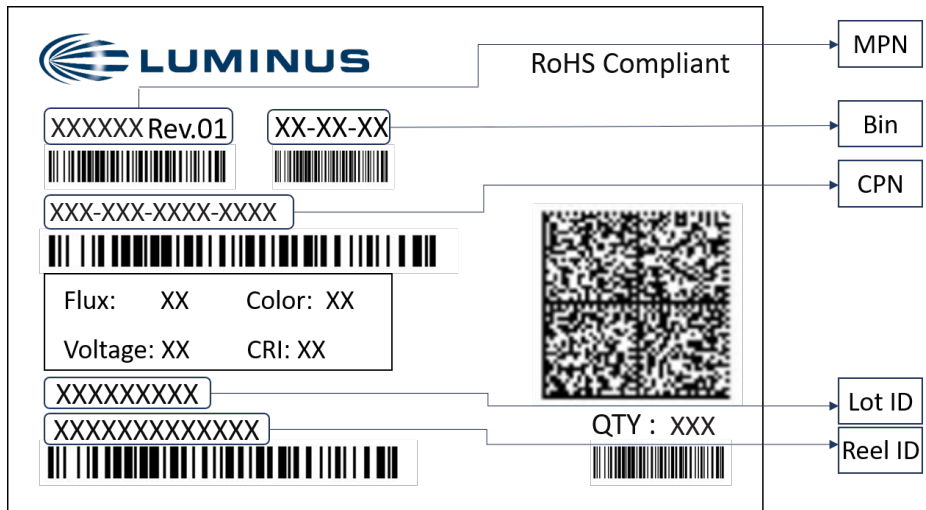

Label Fields:

- CPN:** Luminus ordering part number
- MPN:** For Luminus internal use
- QTY:** Quantity of parts per reel
- Flux:** Bin as defined on page 3
- Voltage:** Bin as defined on page 3
- Color:** Bin as defined on page 4
- CRI:** NA
- Lot ID & Reel ID:** For Luminus internal use



Packaging

Packaged Reel

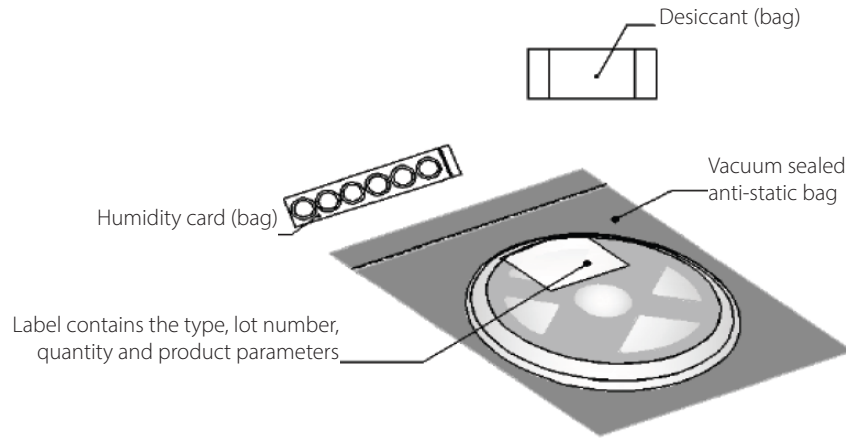

Packaging boxes

Box Size 1 - 5 reels per box
Size: 22.5 x 24.5 x 6.5 cm
Capacity:

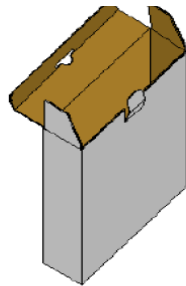

*Capacity 5 reels per box

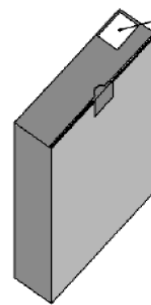

Label contains the type, lot number, quantity and product parameters

Box Size 2 - 10 reels per box
Size: 22.5 x 24.5 x 13 cm
Capacity:

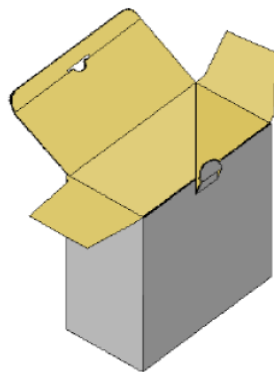

*Capacity 10 reels per box

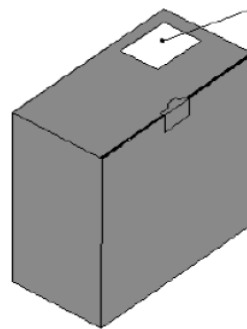

Label contains the type, lot number, quantity and product parameters

Packing Configuration:

- 1,000 units per reel
- Each reel is enclosed in anti-static bag
- Shipping label is placed on top of each reel
- Multiple labels are attached to the box (one label per reel inside the box)



Notes

Static Electricity

1. The products are sensitive to static electricity, and care should be taken when handling them.
2. Static electricity or surge voltage will damage the LEDs. It is recommended to wear anti-electrostatic gloves or wristband when handling the LEDs.
3. All devices, equipment and machinery must be properly grounded. It is recommended that measures be taken against surge voltage to the equipment that mounts the LEDs.

Reference: [APN-002815](#) Electrical Stress Damage to LEDs and How to Prevent It

Storage

1. Before opening the package

The LEDs should be kept at a temperature lower than 40°C and relative humidity lower than 90%. The LEDs should be used within a year. When storing the LEDs, moisture proof package with absorbent material (silica gel) is recommended.

2. After opening the package

The LEDs should be kept at a temperature lower than 30°C and relative humidity lower than 60%. The LEDs should be soldered within 168 hours (7 days) after opening the moisture proof package.

If unused LEDs remain, they should be stored in moisture proof packages, such as sealed containers with moisture absorbent material (silica gel). It is also recommended to return the unused LEDs to the original moisture proof package and to seal it again.

If the moisture absorbent material (silica gel) vaporizes or passes the expiration date, baking treatment should be performed by using the following conditions : 60°C for 20 hours.

The LED's electrode and lead frame comprise a silver plated copper alloy. The silver surface may be affected by environments. Please avoid conditions which may cause the LEDs to corrode or discolor. The corrosion or discoloration might lower solderability or affect optical characteristics.

Please avoid rapid transition in ambient temperature, especially in high humidity environments where condensation can occur.